

## STAR-DELTA TIMER



### Application

This type is for using in “Soft Start” function. It can reduce the overload current effect while Motor starts to run, and also decline the vibration (caused by motor’s activities) to protect the mechanical construction in order to prevent any error on the protection electricity post.

### Features

1. Designed for Inductive Electric Motor Starter use (Y- $\Delta$ ) .
2. The switching time (from Star connection to Delta connection) can be ordered. Usually, it's 0.1 sec. ex-factory.
3. Re-set time is fast and suitable for re-start function.
4. Timing range of 12S/30S/60S is optional.

# Panel Function

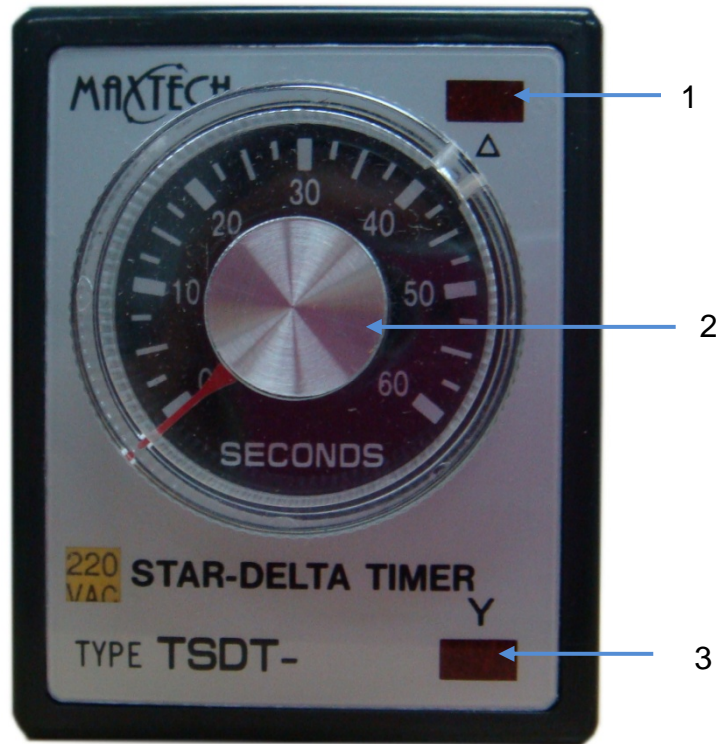

MARKS/DESCRIPTIONDESCRIPTION		
1	Main Control Indicator	Red LED Twinkling Shows "ON"
2	Main Control Setting	Set time
3	Main Control Indicator	Red LED Twinkling Shows "ON"

# Standard Specification

Model		TSDT
Products		
Dimension		61Hx49Wx92D (mm)
Mounting & Socket	Surface(-N)	8PFA
	Flush(-Y)	x
Full Timing Range		12S, 30S, 60S Standard Change time: 0.1S
Rated Voltage		AC(V): 110, 220, 240, 380, 440, 50/60Hz
Contact	Model	A
	Time Limit 1C	5A
	Time Limit 1C	x
	Instantaneous 1C	5A
Mechanical Life		$5 \times 10^6$ TIMES
Electrical Life		$10^5$ TIMES
Accuracy	Repeat Error	$\pm 1\%$ MAX
	Setting Error	$\pm 10\%$ MAX
	Voltage Error	$\pm 1\%$ MAX
	Temp Error	$\pm 2\%$ MAX
Resetting Time		0.3 sec MAX
Consumed Power		2VA
Ambient Temperature		-10°C ~ +55°C
Ambient Humidity		45~85% RH
Weight		230G

# External Dimension

Unit : mm

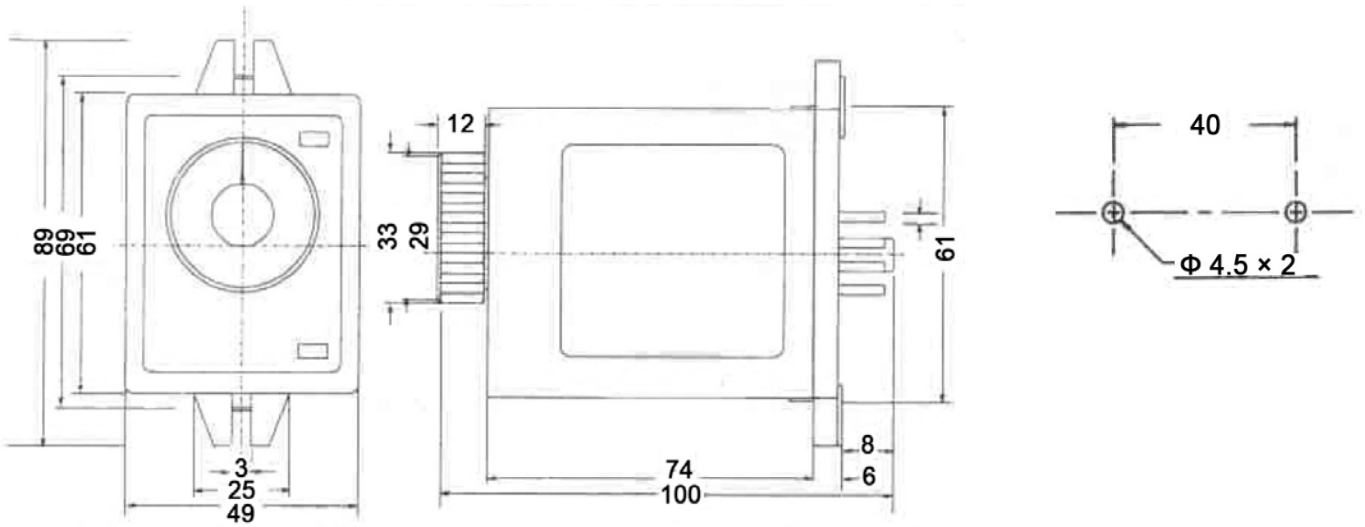

# Socket & Wiring Diagram

Unit : mm

## 8PFA

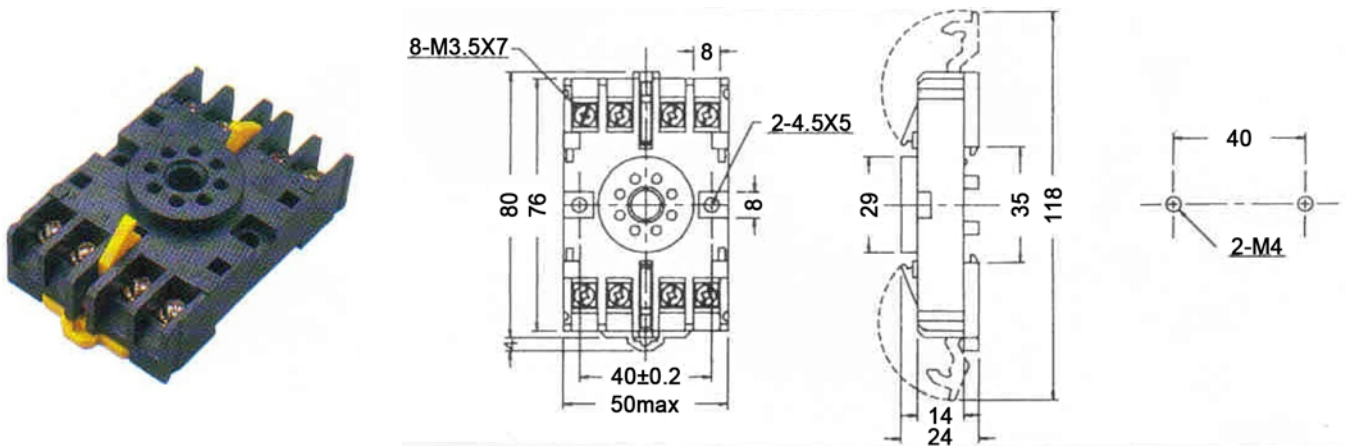

## TSDT-N

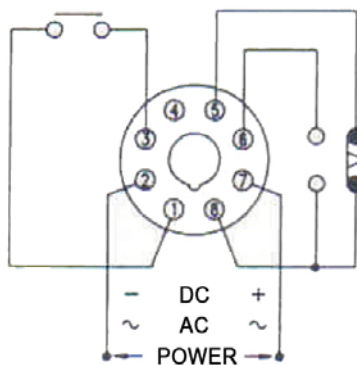

POWER (2-7)

NC (8-5)

NO (8-6)

NO (1-3)

⋈ - LAMP

△ - LAMP

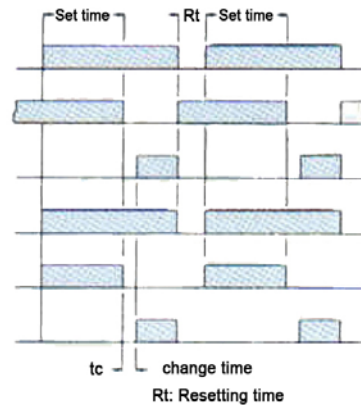

# Contact

## Taipei World Trade Center

Add: 3C22-23 & 3C25-26, Taipei World Trade Center, No. 5, Sec. 5, Hsin Yi Rd. Taipei Taiwan, R.O.C.

Tel: 886-2-27206601 (Rep.)

Fax: 886-2-23455120

E-mail: [gitta@ms9.hinet.net](mailto:gitta@ms9.hinet.net)

<http://www.maxthermo.com>

## Factory

Add: 11F., No.168, Jiankang Rd., Zhonghe Dist., New Taipei City 235, Taiwan (R.O.C.)

Tel: 886-2-22287950 (Rep.)

Fax: 886-2-22286140

## Thailand Office - THAI MAXIMUM ELECTRONIC CO., LTD

Add: 86/132-133 m.7 Samaedum Bangkoontien Bangkok 10150 Thailand.

Tel: +662-415-8318 , +662-417-2548-49

Fax: +662-415-8798

<http://www.thaimaximum.com>