

RS-485電錶 MICROPROCESS RS-485 METER



RS - 40 4 Digital RS-485 Meter
RS - 50 4 1/2 Digital RS-485 Meter



RS - 80 8 Digits RS-485 Meter
RS - 88 Dual 8 Digits RS-485 Meter

Features

- RX .TX indication
- Protocol : Modbus
- DIN Case 96 x 48mm

Specifications

Display :	0.56" Red LED (RS-40 or RS-50) 0.3" Red LED upper, 0.3" Green LED lower
Input signal :	RS-485
Baud rate :	1200,2400,4800,9600 (Option : 19200)
Address :	1 ~ FF
Protocol :	Modbus (Standard)
Operating Temp. :	0~60°C/ Below 80%R.H.
Storage Temp. :	-10~70°C/ Below 70% R.H.
Power Supply :	AC 115/230V±10%, 50/60Hz
Power Consumption :	Approx. 3VA
Weight :	Approx. 450g
Dielectric Strength :	AC 1500V/1min (Input/Power)
Insulation Resistance :	DC 500V, 100MΩ at above terminals
Dimensions :	96(W) x 48(H) x 144(D)mm
Panel Cut-Out :	91.5(W) x 44(H)mm

RS-485 set up program

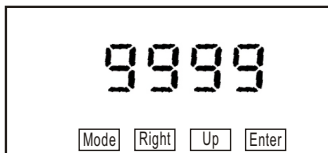

Address : 1 ~ FF
 Baudrate : 9600,4800,2400,1200 (19200)
 Protocol : Modbus RTU Mode

Order Code

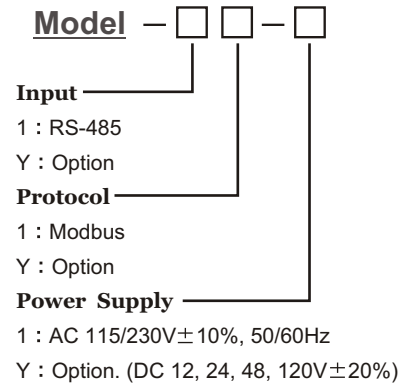

Connection Diagram

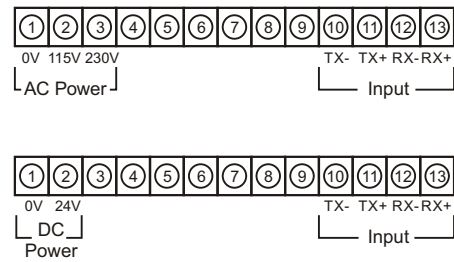

Dimensions

