

3-wire Temperature & Humidity Transmitter for Probe Type



Application

1. Monitoring for HVAC process/ air conditioning/ environmental ventilation control.
2. Environmental monitoring for building/ factory/ clean room/ Lab.
3. Monitoring for storeroom/ crisper/ agriculture/ food industry.
4. Temperature and humidity measuring in machinery equipment.

Features

1. Compact design and easy to install.
2. An economical choice, high C/P ratio.
3. Industrial class sensor comes with high accuracy and long-term stability.

Standard Specification

Input	
Input	Capacitive Humidity Sensor & PT100Ω
Measuring range	Temperature : PT100 ; humidity : 0~100%
Max working range	Temperature 0~50°C ; humidity : 5~95%
Recommended working range	Temperature 15~35°C ; humidity : 20~80%
Output	
Output	Humidity : 0~10V / Temperature : RTD
Signal connection	3-wire
Accuracy	
Temperature	±0.3°C + 0.002°C x tactual
Humidity	±3%RH(30~70%) of F.S. ,at +25°C ±5%RH(20%~80%) of F.S. ,at+ 15~35°C
Load resistance	≥ 10KΩ
Output calibration (ZERO)adjustment degree	10% of zero-point and full-range
Response time(≥ 1m/s)	< 20S
Environment	
Media	Air
Media temperature	0 ~+50°C
Storage temperature	-5~+60°C
Max. flow speed	≤ 15m/sec
Electrical protection	
Power supply	24VDC ±20%
Electrical connection	PVC cable 0.32mm ² *6C
Installation	flange installation
Protection degree	IP24
Electrical protection	■Polarity protection ■over-voltage ■short circuit
Housing	PC fire-proof class
Cable	PVC
Weight	17g(without cable)

External Dimension

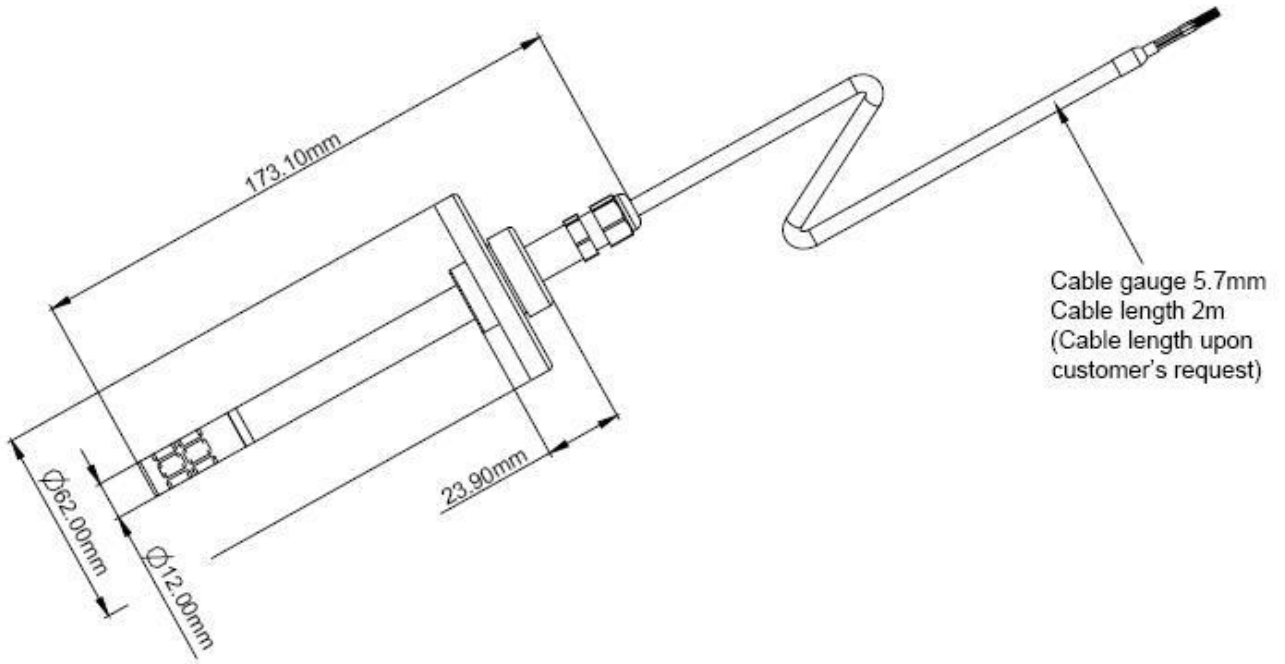

Diagram

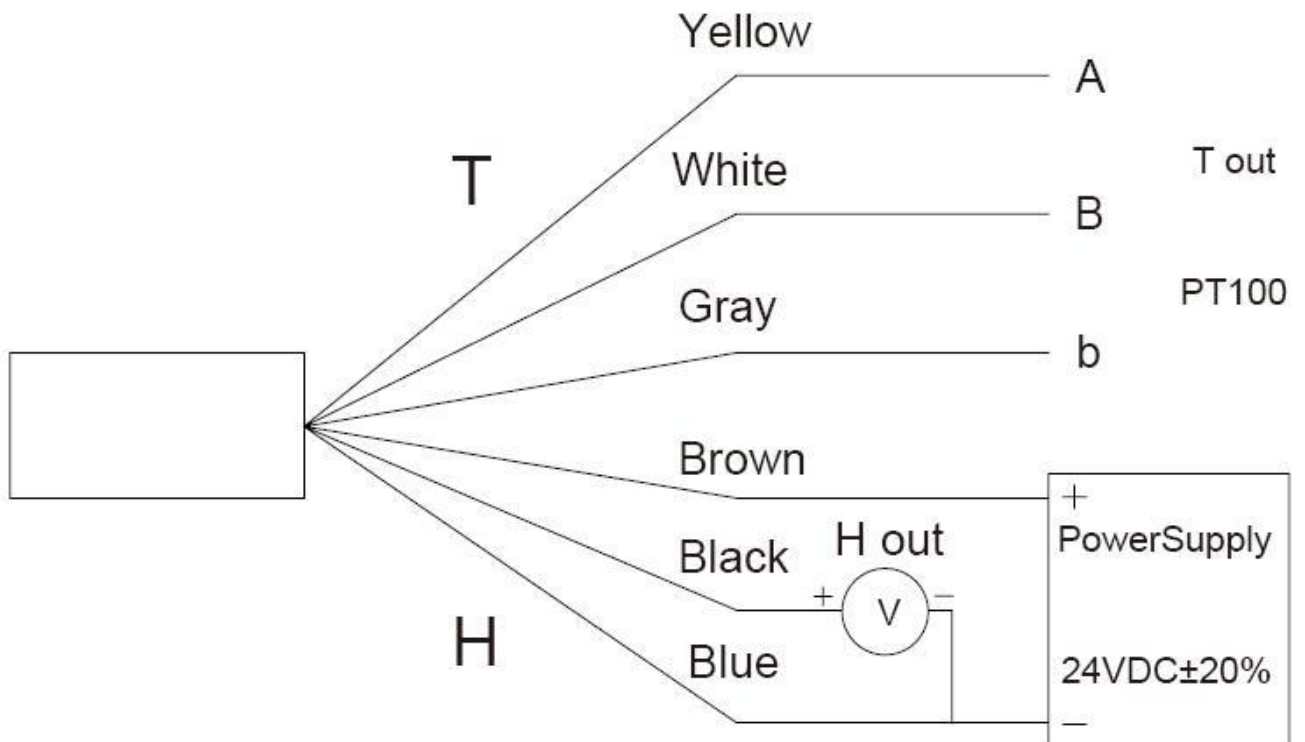

Order information

MTHS -

07

 -

A

J

1

P2

00

2

A B C D E F G

(A) Installation	(B) Function	(C) Output	(D) Power Supply
07 : probe type	A : temperature / humidity output	J : 0~10V(H) & RTD (T)	1 : 24 VDC+/-20%

(E) Temperature Range	(F) Humidity Range	(G) Option
P2 : PT100 NT : NTC10K	00 : 0~100%	2 : 2m cable

Contact

Taipei World Trade Center

Add: 3C25, Taipei World Trade Center, No. 5, Sec. 5, Hsin Yi Rd. Taipei Taiwan, R.O.C.

Tel: 886-2-27206601 (Rep.)

Fax: 886-2-23455120

E-mail: gitta@ms9.hinet.net

<http://www.maxthermo.com>

Factory

Add: 11F., No.168, Jiankang Rd., Zhonghe Dist., New Taipei City 235, Taiwan (R.O.C.)

Tel: 886-2-22287950 (Rep.)

Fax: 886-2-22286140

Thailand Office - THAI MAXIMUM ELECTRONIC CO., LTD

Add: 86/132-133 m.7 Samaedum Bangkoontien Bangkok 10150 Thailand.

Tel: +662-415-8318 , +662-417-2548-49

Fax: +662-415-8798

<http://www.thaimaximum.com>