



**LS700**  
0.2kW~75kW

# LS700 Series *Sensorless* Flux Vector Drive



## Comply with...

-  Environmentally-friendly technology
-  Power-saving technology
-  Innovative technology



CE Approval



We were established in 1985. Our factory is located at Taipei Hsien, Taiwan. For many years, we have been specialized in manufacturing AC vector inverter, DC brushless servo drives, braking unit and periphery equipment, etc. with excellent quality and price, and also our products have been sold all round the world. In 2002, we passed and were recognized by the international quality standard certification ISO9001:2000, which showed our products with much more improved quality and fulfilled out promises and trusts to our customers.

LS700 series is a series of more than perfect AC drives. LS700 series adopts the flux vector control principle with the advanced high technology "direct field excited" to exactly estimate the magnetic flux and also adopts DSP software and hardware to process the engineering calculation for the output conversion of best output torque excited. LS700 series is applied to the control in precision and complex industries and is used in such as AC induction motors, crane equipment, elevators, torque control, Vacuum pump and constant pressure water pump control...etc.

## LS700 Series

Flux vector inverters

Sensorless control

**Voltage Range :**  
200V~240V 1P/3P  
380V~460V 3P

**Capacity Range :**  
0.2KW~75KW



### LS600 Series Inverters

IGBT Space vector inverters

**Voltage Range :**  
200V~240V 1P/3P  
380V~460V 3P

**Capacity Range :**  
0.4KW~75KW



### LS DC Bus choke

**Voltage Range :**  
DC200V~800V

**Capacity Range :**  
0.4KW~300KW



### LS700 Series

Flux vector inverters  
Sensorless

**Voltage Range :**  
200V~240V 1P/3P  
380V~460V 3P

**Capacity Range :**  
0.2KW~75KW



### LS AC output reactor

**Voltage Range :**  
200V~240V 3P  
380V~460V 3P

**Capacity Range :**  
0.4KW~300KW

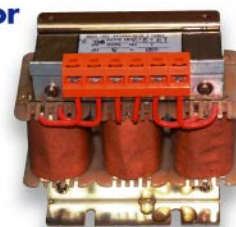

### LS800 Series

Flux vector inverters  
Sensorless & Closed Loop

**Voltage Range :**  
200V~240V 1P/3P  
380V~460V 3P

**Capacity Range :**  
0.75KW~220KW



### LS AC input reactor

**Voltage Range :**  
200V~240V 1P/3P  
380V~460V 3P

**Capacity Range :**  
0.4KW~300KW



### LSBR Series - Brake unit (Simultaneous Gate)

**Voltage Range :**  
200V~230V  
380V~460V

**Capacity Range :**  
0.4KW~300KW



### LSBR Series - Brake resistors

**Capacity Range :**  
100W~10KW

**Resistance :**  
5Ω~500Ω



### EMC Filter

**Voltage Range :**  
200V~240V 1P/3P  
380V~460V 3P

**Capacity Range :**  
0.4KW~220KW



### LS - operation keypad with extension cable



LS600 Model extension cable with operation keypad      External cable with operation box      LS800 Model extension cable with operation keypad



### 3 operational control modes

- Sine wave V/F vector control
- Sine wave V/F sensorless vector control
- Flux vector sensorless control and sensorless speed PI adjustment

### Built-in special practical functions

- Auto-Tuning parameter of motors with precision
  - (1) can automatically detect the motor electricity parameters dynamic and static or Manual key-in motor electricity parameter value
  - (2) The drives can perform auto-tuning with load
- Speed accuracy(±1%)
- Multi-function PID block
- Special PID function for pumping application
- 8 preset speeds control ~ 8 groups of accel/decel time
- Built-in intelligent multi-functional parameter group specialized for water pump
- S ramp, linear ramp and V/F curve are programmable
- Slip and rotational torque are compensated automatically
- AVR automatic voltage regulation control

### Built-in Multi-Function I/O

- 8 sets of Digital-Input can perform multi-function application
- 1 set of Digital-Output can perform multi-function application
- 1set of Relay can perform multi-function application output
- 2 sets of Analog-input (5 selection of inputs condition)
- 1 set of Analog-Output can perform multi-function application

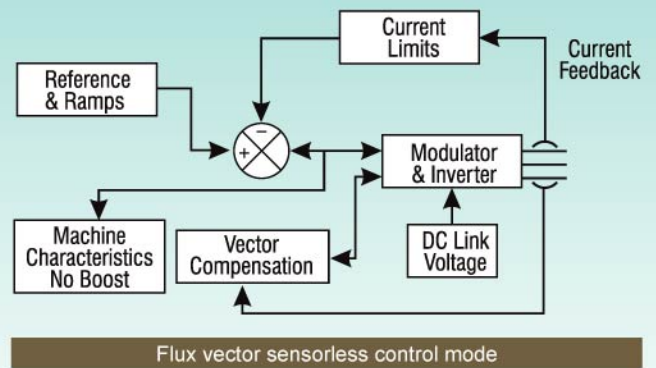
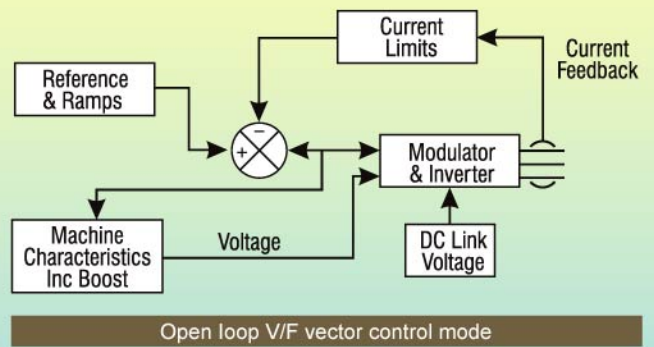

### LS700 special-purpose form

- May simulate the keypad by PC, to operate the drive or to show all the parameters on the PC
- Indicate the parameter, read parameter.....etc
- May select and set the parameter by shipping way (not any by sequence)



Communication

Parameters list

Display all parameter value

Display the unit

Display the parameter name and the scope

Display the parameter value

Simulation Frequency setting

Reads the parameter

Parameter	Description	Value	Scope
F-0	Save the current parameters	(0-1)	20
F-1	Water pressure see value	(0.0-10.0)	0
F-2	Pass word entry to protect the water pump parameters	(-32767-32767)	2,0000
F-3	Reserved	(-32767-32767)	2
F-4	Select the variables to be displayed in operation panel	(0-16)	0
F-5	Unit of speed display	(0-1)	0
F-6	Display of filtration time	(0-15)	0
F-7	Operation control source	(0-1)	1
F-8	Rpm command source	(0-8)	5,0
F-9	Start method	(0-1)	.0
F-10	Braking duration before start	(0-3000.0)	5,0
F-11	Brake voltage before start	(0-20.00)	.0
F-12	Stop mode	(0-2)	.0
F-13	Stopping & braking voltage	(0-20.00)	0
F-14	Stopping & braking time	(0-3000.0)	.0



## Schedule of Control Terminal Function

Terminal Mark	Designated function	Descriptions	
Multifunctional DI terminals	Di1	Forward rotation command	Di1-COM ON for forward, and OFF for stop
	Di2	Reverse rotation command	Di2-COM ON for reverse, and OFF for stop
	Di3	Input at external failure (NC)	External fault.
	Di4	Failure reset	Di4 failure releases, reset the drive
	Di5	Multi-speed command 1	4 preset speeds by BCD code
	Di6	Multi-speed command 2	4 preset speeds by BCD code
	Di7	Inching operation	To execute inching frequency operation
	Di8	E-stop	When activated ON, ac drive stops outputting voltage immediately.
COM	Common terminal for digital input/output	Common terminal for multifunctional DI and DI/O	
Analog frequency setup	+10V	+15V power supply for encoder	Power supply outputs DC+15V (maximum current 30mA) for encoder
		+10V power supply for setting up frequency	Power supply outputs DC+10V for speed reference (maximum current 10mA)
	Note 1	To output +10V or +15V is determined by the J4 setting; +10V is default output set at ex-factory.	
	AVG	0V	0V for AI and AO
Multifunction DIO terminals	AI1	Analog voltage frequency reference	Input impedance 30kΩ at input voltage DC 0~10V or input impedance 500Ω at input current DC 0~20mA is determined by the J3 command selected from the voltage or current signal.
	AI2	Analog voltage frequency reference	Input impedance 30kΩ at input voltage DC 0~10V
Multifunction D/O terminals	AO	Analog output	Multifunctional analog output (DC 0~10V)
	DO	AI Speed	This contact will be enabled 'ON' status when output frequency of ac drive reaches the frequency setting (F62).
	Note 2	It can only have one choice, either AO or DO, as a synchronous setting output made by software and hardware J1. Software AO is to be established by parameters F50 ~ F52 while software DO is to be set up by parameter F62.	
	COM	Common terminal for signal input/output	Common terminal for signals from multifunctional input/output terminals.
	Ta		The relay will be enabled when the drive trip
	Tb	Output at failure (NC)	* Ta-Tc is closed when drive trip
	Tc		* Tb-Tc circuit is opened when drive trip
E	Terminal for grounding	Ground terminal	

## Control Circuit Wiring Diagram

Terminal wiring for control circuit of ac drive

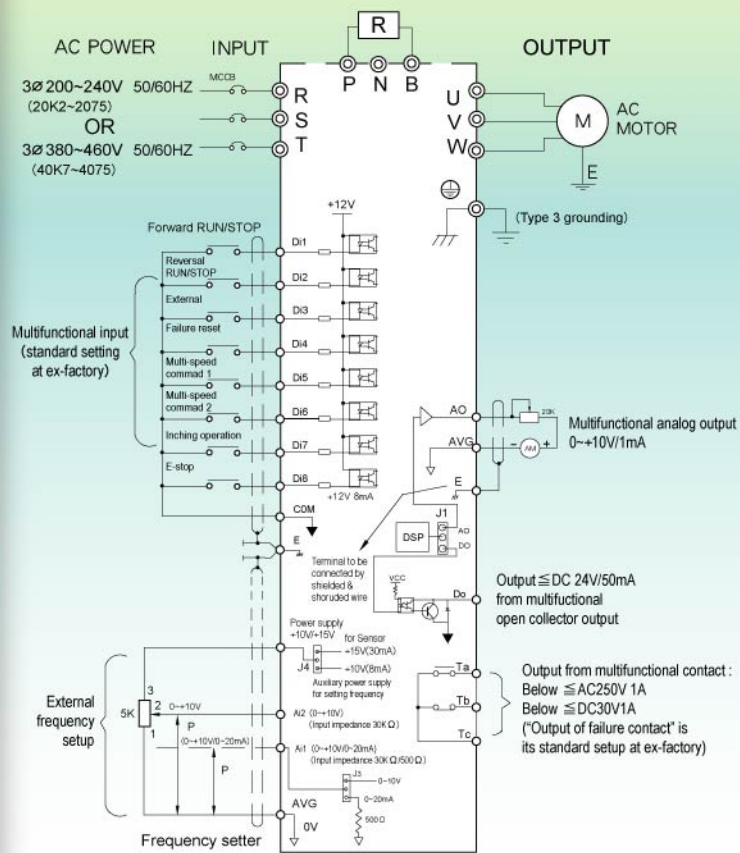

LS700M-20K2-TN  
LS700M-20K4-TN  
LS700M-20K7-TN  
LS700M-21K5-TN

LS700-20K4-TD  
LS700-20K7-TD  
LS700-21K5-TD  
LS700-22K2-TD

LS700-22K2-TD  
LS700-24K0-TD  
  
LS700-42K2-TD  
LS700-44K0-TD

LS700-25K5-TD  
LS700-27K5-TD  
LS700-2011-TD  
  
LS700-45K5-TD  
LS700-47K5-TD  
LS700-4011-TD

LS700-2015-TN LS700-2018-TN  
LS700-2022-TN LS700-2030-TN  
  
LS700-2037-TN LS700-2045-TN  
LS700-2055-TN LS700-2075-TN  
  
LS700-4015-TN LS700-4018-TN  
LS700-4022-TN LS700-4030-TN

LS700-4037-TN LS700-4045-TN  
LS700-4055-TN LS700-4075-TN



# Model Instructions

## LS700 Series Flux Vector Drive Sensorless



**LS700-24K0-XXXX**

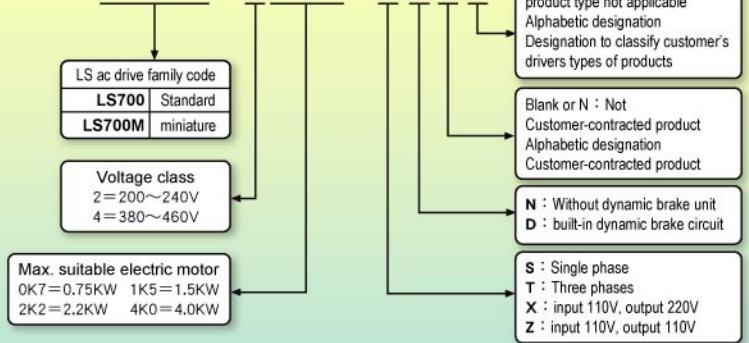

### Standard Specifications

200V Series	LS700 Model	20K2	20K4	20K7	21K5	22K2	24K0	25K5	27K5	2011	2015	2018	2022	2030	2037	2045	2055	2075
	Max Motor (KW) for Drive	0.2	0.4	0.75	1.5	2.2	4.0	5.5	7.5	11	15	18.5	22	30	37	45	55	75
	Output Capacity (KVA) of Drive	0.6	1.0	1.7	2.8	4.2	6.0	9.1	12.2	17.5	23	29	34.7	44	55	67	82	110
	Rated Current (A) of Drive	1.6	2.5	4.5	7.5	11	17.5	24	33	46	61	76	90	115	145	175	215	300

400V Series	LS700 Model	40K7	41K5	42K2	44K0	45K5	47K5	4011	4015	4018	4022	4030	4037	4045	4055	4075
	Max Motor (KW) for Drive	0.75	1.5	2.2	4.0	5.5	7.5	11	15	18.5	22	30	37	45	55	75
	Output Capacity (KVA) of Drive	2.0	3.2	4.2	7.0	9.5	13	18	23.5	29	33	46	53	68	84	110
	Rated Current (A) of Drive	3.2	4.5	7.0	9.0	12	17	23	30	38	43	58	70	85	110	150

Item		200V Rating		400V Rating	
Power Source	Power Voltage, Frequency	Single-phase / Three phase 200V-240V 50 / 60Hz		Three phase 380V-460V 50 / 60Hz	
	Allow Voltage Variance	±10%			
	Allow Frequency Variance	±5%			
	Max. Output Voltage	Three phase corresponds to Input voltage		Three phase corresponds to Input voltage	
	Rated Output Frequency	0.01Hz~240Hz			
Control Characteristics	Control Model	Sine wave SVPWM, carrier frequency 2K~16KHz adjustable, choose one of 3 control modes : V/F, V/F sensorless, flux vector sensorless			
	Starting Torque	150% / 1Hz			
	Range of Speed Control	1 : 100			
	Precision of Speed Control	±1%			
	Control Function	15 indications, 9 command sources of rotation speed, speed searching, torque limits, multi-function input and output terminal, 8 preset speeds control, skip frequency, AVR, Auto-Tuning motor parameters, s curve, slip compensation, torque compensation, MAX and Min frequency setting, DC brake in start/stop, PID function, Water pump special-purpose PID, intelligent water pump Application function			
	Frequency Precision (Temperature Variation)	Digital signal : ±0.1% (-10°C~+40°C)		Analog signal : ±0.1% (25°C ±10°C)	
	Frequency Setting Resolution	Digital signal : 0.01%Hz (0.01~240Hz)		Analog signal : 0.06 / 60Hz	
	Frequency Output Resolution	0.01Hz			
	Overload Capacity	Rated current 150%, 1 Min.			
	Analog Setting Signal	DC 0~10V, 0~20mA			
Protection Function	Speed Acc/Dec	0.1 sec~600sec, adjustments are individually distributed to 8 speeds			
	Torque for Braking	About 20%, up to 125% with braking unit			
	Motor Protection	I <sup>2</sup> · t electrical thermo protection			
	Instantaneous Over Current	When over 200%rated current drive trip, motor stops			
	Overload	About 150% rated output current, 1 Min, Drive trip			
	Over Voltage	DC voltage in main circuit about 400V, motor stops		DC voltage in main circuit about 800V, motor stops	
	Low Voltage	DC voltage in main circuit below 180V, motor stops		DC voltage in main circuit below 3800V, motor stops	
	Power Protection	Input phase loss (equipped above 5.5 KW), output phase loss protection (equipped above 0.4KW)			
	Ventilation Over-heat	Protected, by thermo-switch, can be read and monitored			
	Stall Prevention	In speed Acc/Dec, stall prevention during operation			
Environment	Ground Protection	Electrical circuit protection			
	Charging Indicating	DC voltage in main circuit over 50V, charging light is "on"			
	Location	Indoor, no corrosive and free from dust			
	Ambient Temp	-10°C~+40°C(closed and wall mounted type), -10°C~45°C(open type), no freezing			
Storage Temp (Note 2)	-20°C~+60°C				
Humidity	Below 90% RH (no condensing)				
Vibration	1G below 20Hz, 0.2G during 20~50Hz				

(Note 1) Max. applicable capacity of motor is based on 4-pole motor.

(Note 2) If storage temperature is too high, it might destroy the capacitor in main circuit.

Dimension UNIT : mm

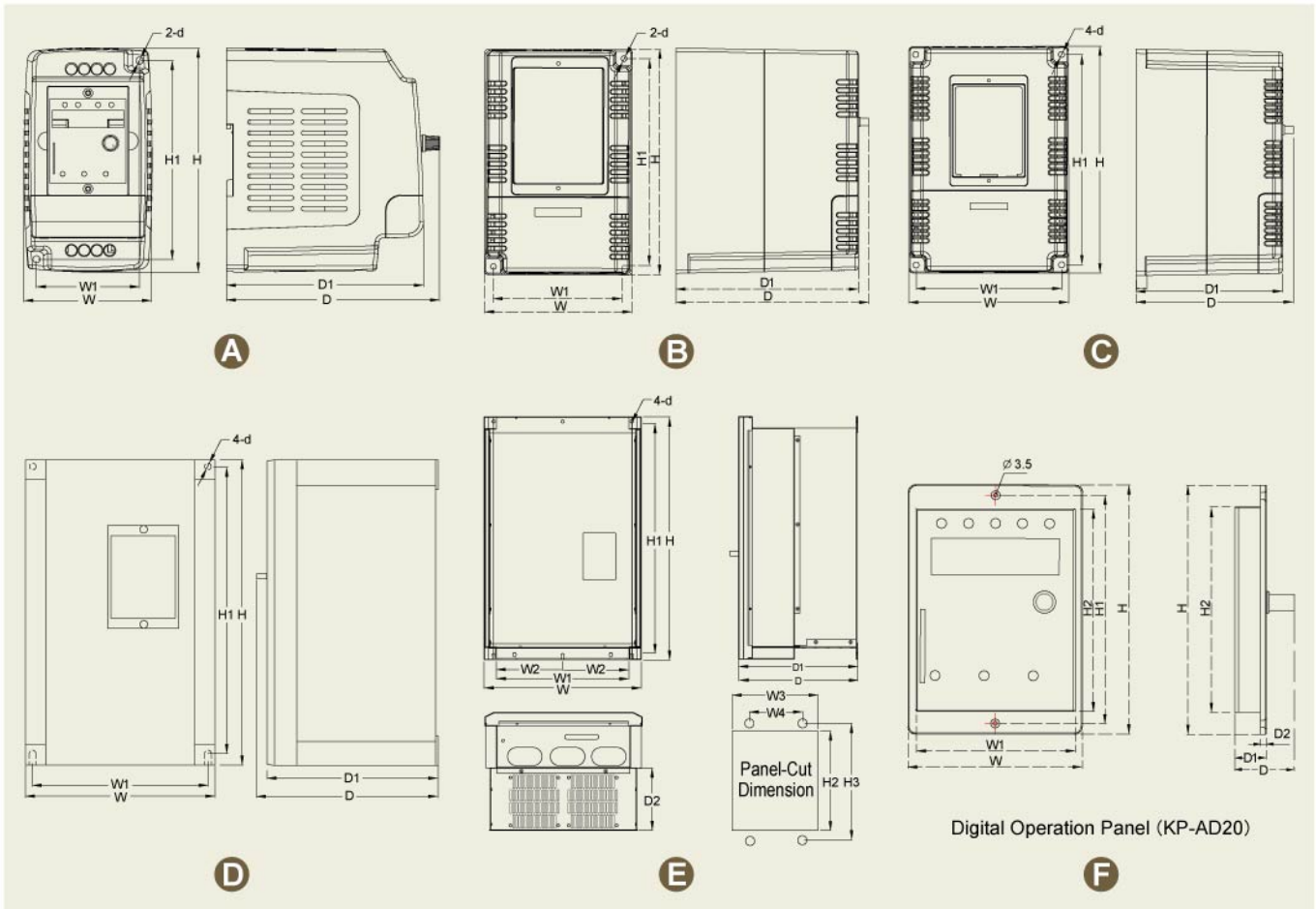

LS700 Specification Dimensional Drawing

Model	Dimensions (mm)			Fixed size (mm)				∅	Semi-embedded Opens the hole • Fixed size (mm)					Figure No
	W	H	D	W1	W2	H1	D1		d	W3	W4	H2	H3	
LS700M-20K2 · LS700M-20K4	82.5	145	138	66.5	—	128.5	127.5	4.6	—	—	—	—	—	A
LS700M-20K7 · LS700M-21K5														
LS700-20K4 · LS700-40K4	114	172	146	101	—	159	136	5.3	—	—	—	—	—	B
LS700-20K7 · LS700-40K7														
LS700-21K5 · LS700-41K5	152	214	146	137.5	—	200	136	5.3	—	—	—	—	—	C
LS700-22K2 · LS700-42K2														
LS700-24K0 · LS700-44K0	188	300	180	170	—	283	170	7	—	—	—	—	—	D
LS700-25K5 · LS700-45K5														
LS700-27K5 · LS700-47K5	250	420	227	218	—	401	217	7	242	170	407	422	112	E
LS700-2011 · LS700-4011														
LS700-2015 · LS700-4015	345	533	272	305	152.5	515	262	7	330	212	515	538	140	E
LS700-2018 · LS700-4018														
LS700-2022 · LS700-4022	70.9	102	25.8	—	—	93	15.8	3.5	65.3	—	84.5	—	—	F
LS700-2030 · LS700-4030														
LS700-2037 · LS700-4037	KP-AD 20	—	—	—	—	—	—	—	—	—	—	—	—	F
LS700-2045 · LS700-4045														
LS700-2055 · LS700-4055	—	—	—	—	—	—	—	—	—	—	—	—	—	—
LS700-2075 · LS700-4075														